

REGISTERED/IMMEDIATE

Heavy Industries Taxila

Gun Factory

Taxila Cantonment

Tel: 051- 9270571-4/62739

7885/227/IT-04/Dead Centre/MD GF

05 December 2024

To: M/s _____

Subject: **Tender Inquiry (FOR)**

1. You are requested to please forward your offer for the following:-

S/No	Part no	Nomenclature	A/U	Qty
1.	P-885/46T-155	Dead Centre (Detail attached as per Annexure 'A')	Nos	10

Instructions to the Bidders

2. Rates will be quoted on FOR Taxila Cantt basis. Offer best competitive price while submitting your quotation.

3. Over writing and cutting of any nature in the quotation will not be accepted.

4. Part-I and Part-II quotations will be enclosed in separate sealed envelopes for each tender inquiry. For identification purpose, the words "TECHNICAL QUOTATION PART-I WITHOUT PRICE" and COMMERCIAL QUOTATION (PART-II) WITH PRICE" shall be written in BLOCK CAPITAL LETTERS on the respective sealed envelopes which will be placed in a large envelope bearing complete details of the tender inquiry as under :-

BID**REGISTERED****TENDER INQUIRY NO. 7885/227/IT-04/Dead Centre/MD GF dated 05 December 2024****TO BE OPENED ON 1100 hours on 26 December 2024**

To: MANAGING DIRECTOR GUN FACTORY, MAIN GATE GUN FACTORY HEAVY INDUSTRIES TAXILA, TAXILA CANTT, PAKISTAN

FROM: M/s _____

5. **Delivery of Tender.** The tender/bid will be enclosed in a sealed cover which will be invariably marked with "Bid against tender inquiry no. **7885/227/IT-04/Dead Centre/MD GF dated 05 December 2024**" and complete address. The tender if brought by hand, will be handed over to security staff on duty at Main Gate Gun Factory for placing the same in bid box (available at gate). The bid will not be brought by hand by any firm while visiting the office of Assistant Director (Coordination). Moreover, if required endorsement are found missing, the bid will be liable for rejection.

6. The bid must be dropped in the bid box, latest by **1030 hours** on **26 December 2024** at main Gate Gun Factory. The bid will be opened same day at **1100** hours in the presence of the available representative of the firms in Gun Factory, Heavy Industries Taxila. No bid will be entertained / considered after **1030 hours**, on the aforementioned date.
7. All paper must be signed and stamped and items not quoted / quoted must be mentioned clearly.
8. All clauses / term mentioned in this inquiry will be considered accepted by the bidding firm, ever if no reference to them is given in the respective offers.
09. **Postal order for Rs.200/-** (Rupees Two Hundred) in favour of MD GF, HIT Taxila Cantt will be invariably be enclose with the offer, failing which the bid will be ignored.
10. Firms are instructed NOT to send Telex and Fax Bids. Such Bids / Offers would not be accepted.
11. Following conformation regarding availability of the advance sample be endorsed by all bidders in their quotation:-

"It is confirmed that drawings and technical specifications against all the items of the bid are readily available. Same can be collected from Gun Factory"
12. Please confirm receipt of the tender inquiry immediately and also intimate your participation is otherwise in this tender inquiry. In case any firm does not wish to bid, then it should return the tender inquiry documents at the earliest.
13. HIT reserves its right to cancel the bidding process with reasons but without any obligation to justify such a reason.
14. The stores are required to be delivered at Gun Factory, Taxila Cantt within **04 x months** from the date of signing of the contract.
15. The offered price quoted must be firm, final and inclusive of all taxes, packing, handling charges etc and delivery at HIT Taxila Cantt.
16. **Offers must remain valid for 180 days** from the date of opening of the tender.
17. The store will be packed in standard grade, worthy of transportation by the means adopted.
18. This inquiry may not be taken as an indication of subsequent supply order and does not in any way commit HIT to purchase the items offered.
19. Warranty period will be one year from the date of issuance of last **CRV** of the stores.
20. Advance sample must be provided (Mandatory) by participating firm's alongwith technical quotation and qualified from QC department of Gun Factory. Preference will be given to those firms having qualified sample.

21. In case of failure to supply the stores within the stipulated periods, liquidated damaged at the rate of 2% but not less than 1% of amount in word per month and maximum value not more than 10% of contacted store value are a part their-of will be levied.

22. **Payment terms**

- a. Payment will be made by either by CMA (DP) Rawalpindi or CMA HIT Taxila Cantt, through cheques against pre-receipted bills (duly affixed with revenue stamps) alongwith professional tax certificates (attested Photocopies) of the supplier after delivery and acceptance of stores.
- b. Partial payments against partial deliveries will be allowed.
- c. The payment to the registered persons is linked with active taxpayer status of the supplier as per FBR data base. If any registered supplier is not on active taxpayer list, his payment will be stopped till he / she files his / her mandatory returns and appears on ATL of FBR.
- d. As per Stamp duty act 1899, firm is liable to pay stamp duty taxes at the rate of 25 paisa per Rs. 100 the said duty should be deducted by CMA from subsequently payment.

23. HIT reserves the right to increase / decrease the quantity of items, placed on the tender without any reference to the firm.

24. The suppliers shall furnished a **5%** performance bank guarantee (PBG) within one month from the date of signing of the contract from a scheduled bank in Pakistan against the value of contract excluding taxes / duties. This bank guarantee must remain valid for 12x month after the stores are put in operation. Performance Bank guarantee will be released on the completion of warranty period of store. In case the firm failed to provide a/m performance Bank Guarantee within the stipulated time period, the contract will be cancelled and Bid security will be enchased. Moreover, the contract shall than be awarded to the next best evaluated bidder.

25. **All Firms participating in the tender will be deposit 2% bid security of total quoted value in the shape of CDR / bank guarantee addressing to Managing Director Gun Factory, Heavy Industries Taxila. The bid security will be provided by the firms in the respective commercial envelopes and clear mentioning of same in the technical quotations, will be ensured by the firms, failing which the bid will stand rejected. The bid securities will be returned as under:-**

- a. **Unsuccessful Bidders. Within 15 days of completion / announcement of the bid evaluation result.**
- b. **Successful Bidders. Upon submission of 5% PBG (para 24).**

26. The net offered price will be Inclusive of 18% GST as imposed by Government of Pakistan. The offer without mentioning of 18% GST will not be considered. The GST will always be mentioned separately to the base price.
27. Integrity Pact will invariably be involved / invoked when the total value of the contract exceeds 10 million as specified in PPRA Rule 2002-2004.
28. In case of any dispute regarding the terms and conditions and the quality of stores, the decision of the Chairman HIT will be considered as final and binding on the suppliers/firms.
29. In case the contracted firm fails to execute the order within the stipulated time and does not materialize the supply of ordered stores, the supply order/contract would be cancelled at the firm's risk and expense. Expenditure incurred on the re-purchase of offered stores will be recovered from the defaulting firm, under existing procedures.
30. Inspection of the stores will be carried out at Gun Factory, Taxila Cantt.
31. Samples for consultation / reference will not be provided, however if drawing is available than the same may be handed over to best evaluated bidder. Samples are available in Gun Factory for convenience of the firms.
32. Technical & Commercial Quotations must be provided on **CDs in MS EXCEL, MS WORD or MS ACCESS** format alongwith hard copies. **Quotations without CDs will not be entertained. Also ensure following while preparing bids:-**
- a. **Sequence of serial no as given in tender inquiry will not be changed.**
 - b. **No serial no will be deleted or short listed in the bid/offer.**

Eligibility Criteria

33. Firms should not be blacklisted or defaulted anywhere within or outside Pakistan. In this regard the firms shall provide **"No Blacklisting Cert / Defaulting Cert"** (Affidavit on Judicial Stamp as per Anx 'B' duly attested by Notary Public, to be provided).
34. Only registered supplier/person who are on Active Taxpayer List (ATL) of FBR are eligible to supply goods/services to government departments. Thus the bidder will submit a certificate to this regard alongwith Technical bid.
35. **Country of Origin:** Pakistan.
36. In case of indigenously / locally manufactured item, the firm should have relevant experience and capacity of manufacturing these parts and should be qualified by quality control department of Gun Factory. Capacity for manufacturing of parts will be verified by a team Gun Factory.
37. Confirmation of the part numbers and nomenclature of required parts alongwith soft copy of same in MS Excel format. The confirmation to fulfill the technical specifications related to each item must be highlighted in the technical bid.

38. In the case of **FOR** imported items, the firms are responsible to provide evidence of the agency agreement /certificate of conformance, principal proforma invoice (in original and without price) and OEM certificates of all the items being quoted against this tender inquiry along with countries of origin. Separate OEM certificate for each / major assembly will be provided by the firms. The firms will clearly indicate that all the parts used in the manufacturing (in case of assembling) are brand new from current production. Conformation to fulfill technical specification related to imported items on FOR basis must be highlighted in the technical bid.
39. Conformation of the validity period of the quote, delivery period and warranty period.
40. Conformation of the willingness of the firm to arrange the visit of a Two member HIT team (ex **Gun Factory, HIT Taxila**) on firm expenses for ascertaining / validating the manufacturing, stocking and financial capability quoted.
41. Confirmation of all technical parameters specified in the IT or confirmation as per sample.
42. Confirmation of manufacturer, brand and approval of advance sample as per specifications mentioned in IT. **Manufacturer brand of each items must be highlighted and the bid.**

Force Majeure

43. Force Majeure means an event in beyond the reasonable control of a Party, is not foreseeable, is unavoidable, and its origin is not due to negligence or lack of care on the parts of a Party, and which makes a Party's performance of its obligations hereunder impossible or so impractical as reasonably to be considered impossible in the circumstances and includes, but is not limited to War, Riots, Civil Disorder, Earthquake, Fire, Explosion, Strom, Flood, Epidemics or other adverse weather conditions, Strikes, Lockouts or other Industrial Action (except where such strikes, lockouts or other industrial action are within the power of the Party invoking Force Majeure to prevent), confiscation or any other action by Government agencies .

Supplier will inform about Force Majeure within specified period of occurrence of such situation. Force Majeure will be effective only, if Purchaser is satisfied that circumstances are beyond the control of supplier.

Failure and Termination

44. If the Supplier fails to deliver the stores within the period prescribed, then on the expiry of 21 days (grace period) the Purchaser shall be entitled at his option to take either of the following actions:-

- a. **Cancelation of Contract on Risk & Expense.** To cancel the contract and / or purchase elsewhere if supplier fails to deliver the contracted store within the delivery period after expiry of 21 days grace period. The Supplier shall also be liable for any loss which the Purchaser may sustain on this account but shall not be entitled to any gain if made during repurchase.
- b. **Imposition of Liquidated Damages.**
- (1) To make the Supplier pay agreed liquidated damages for the period of delay up to the rate of 2% but NOT less than 1% of the value of the late supplied items per month or part thereof for the period exceeding the original delivery period subject to the provision that the total liquidated damages levied will NOT exceed 10% of the total FOR value.
 - (2) HIT shall apply Liquidated Damages (LD) for late delivery, damages and / or risks caused to HIT resulting from the contractor's delays of breach of its obligations as per contract.
 - (3) In case of firm failure to supply the store within the stipulated periods, liquidated damages at the rate of 1% -2% of amount involved per month but not more than 10% of contracted store value or a part there-of will be levied. Grace period of 21 x days would be included for imposition of LD Charges. No grace period will be allowed on already extended DPs.
 - (4) Following consideration will be kept in mind while imposition of LD charges:-
 - a. Firm intimation for extension in DP at least one month before expiry with valid justification.
 - b. Period during production / action has been stopped by the User / Indenter / technical authority due to some reasons.
 - c. All abnormal period taken by the technical authority in clearing each and every lot, because any delay in clearing in first lot, automatically causes the delay in production of subsequent lots.
 - d. Delays in PSI / ATPs / Trials
 - e. Effect of the late delivery of store on project timelines.
 - f. Procedure to be followed:-

- i. HIT will retain the LD charges from each CRC amount being released.
- ii. HIT will process the case file for final decision on Imposition / non imposition of LD charges once complete store is received. However the firm's stance will also be obtained before processing the case for LD charges imposition
- iii. LD charges will be imposed when HIT is satisfied that the failure to supply the store within the schedule DP has been for reason within the control of the supplier, and / or if HIT has suffered loss due to delays in delivery.
- iv. LD charges will be imposed thorough amendment in contract within 60 days from CRC.
- v. A copy of amendment will endorsed to CMA (HIT) Taxila Imposition of LD charges will be notified to CMA (HIT) Taxila for necessary recovery.

Qualification Criteria.

45. Participating firms should meet the following criteria with:-
- a. 50% score in every individual category / sub category.
 - b. 70% aggregate score of all categories.
 - c. The scoring would be done as under:-

(1)

Ser	Description	Maximum Points
(a)	Financial Soundness	15
(b)	Past Experience / Record	15
(c)	Past Performance	20
(d)	Technical specifications / parameters	50
Total		100

46. Only affidavits and third party (having no conflict of interest with either HIT or the bidder) generated / verified documents may be treated as credible evidences for scoring.

47. Contracts will be awarded to **best evaluated bidder** with highest overall score on **weight age which will be worked out as under:-**

- | | | | |
|----|--------------------------|---|------------|
| a. | Qualification Criteria | - | 70% |
| b. | Commercial offer / Price | - | 30% |

Note: Technical / Commercial quotation must conform to IT parameters specified in this tender. The offer will be rejected there in if the said parameters are not complied with.

48. The participating firms must visit the Gun Factory, Heavy Industries Taxila to check / evaluate the machine on site prior to participating in tender inquiry.

Works Manager
For Managing Director
(Nauman Ahmed)

Annexure "A"

Ser	Part No	Nomenclature	Quantity	Drawing / Specification
1.	P-885/46T-155	Dead Centre	03	Appendix – I to Annexure "A"
2.	P-885/46T-155	Dead Centre	03	Appendix – II to Annexure "A"
3.	P-885/46T-155	Dead Centre	04	Appendix – III to Annexure "A"

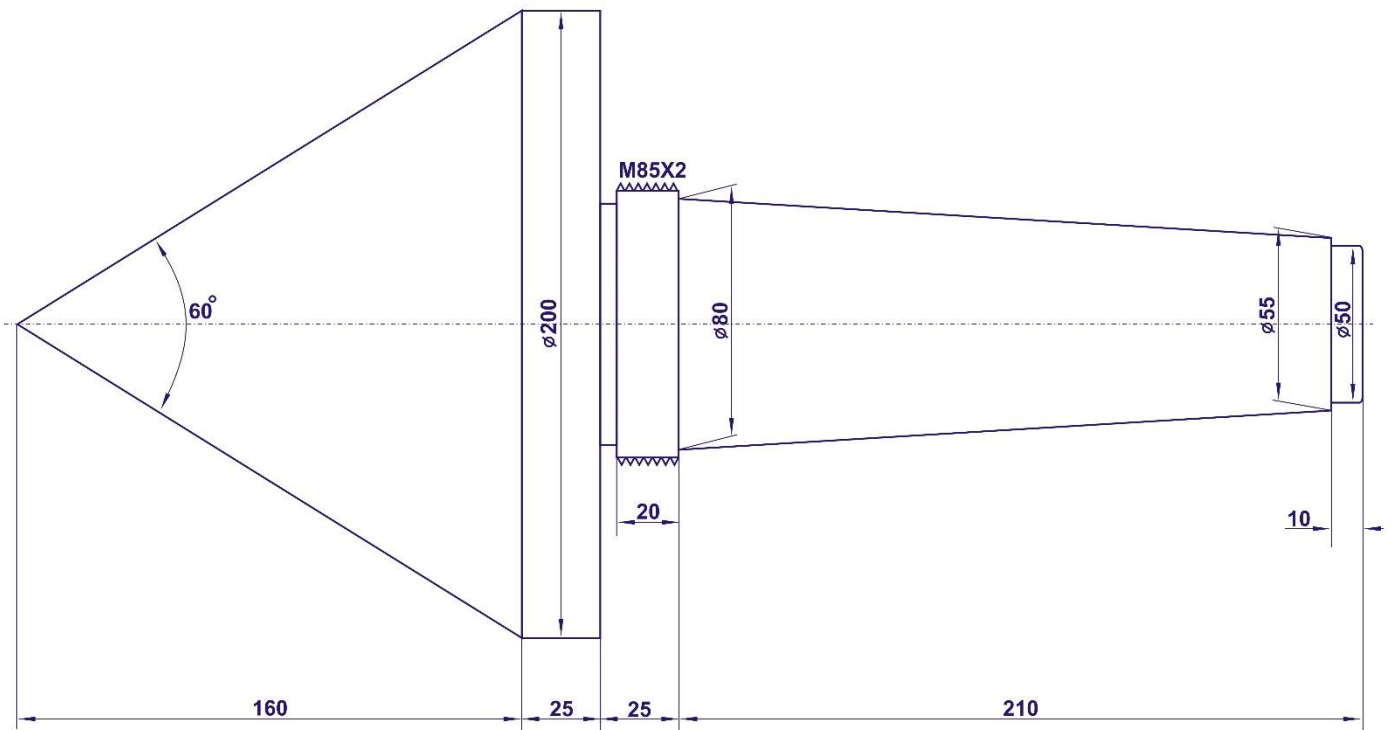
Appendix – I to Annexure "A"**DEAD CENTRE**

Note: Run - Out of Centre Ground Shall not Exceed 0.05 mm with respect to Taper

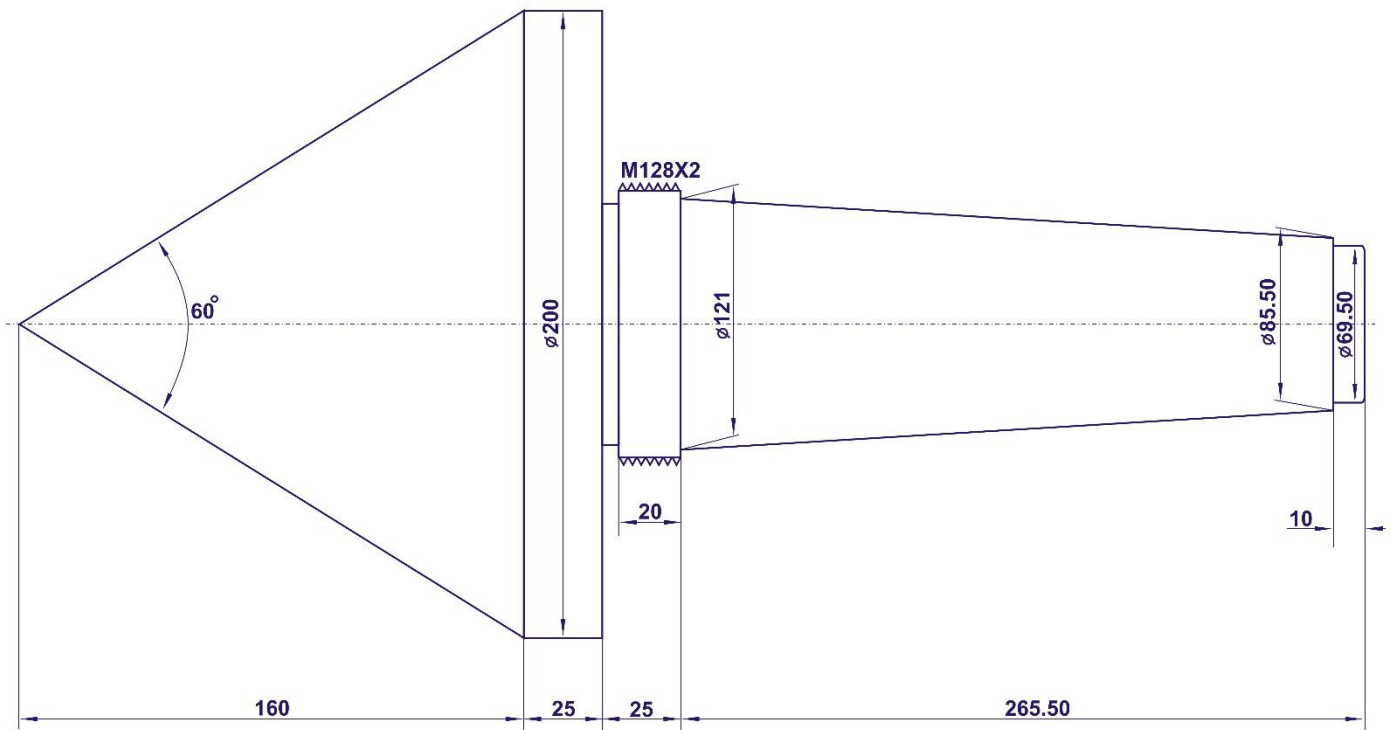
Appendix – II to Annexure "A"**DEAD CENTRE**

Note: Run - Out of Centre Ground Shall not Exceed 0.05 mm with respect to Taper

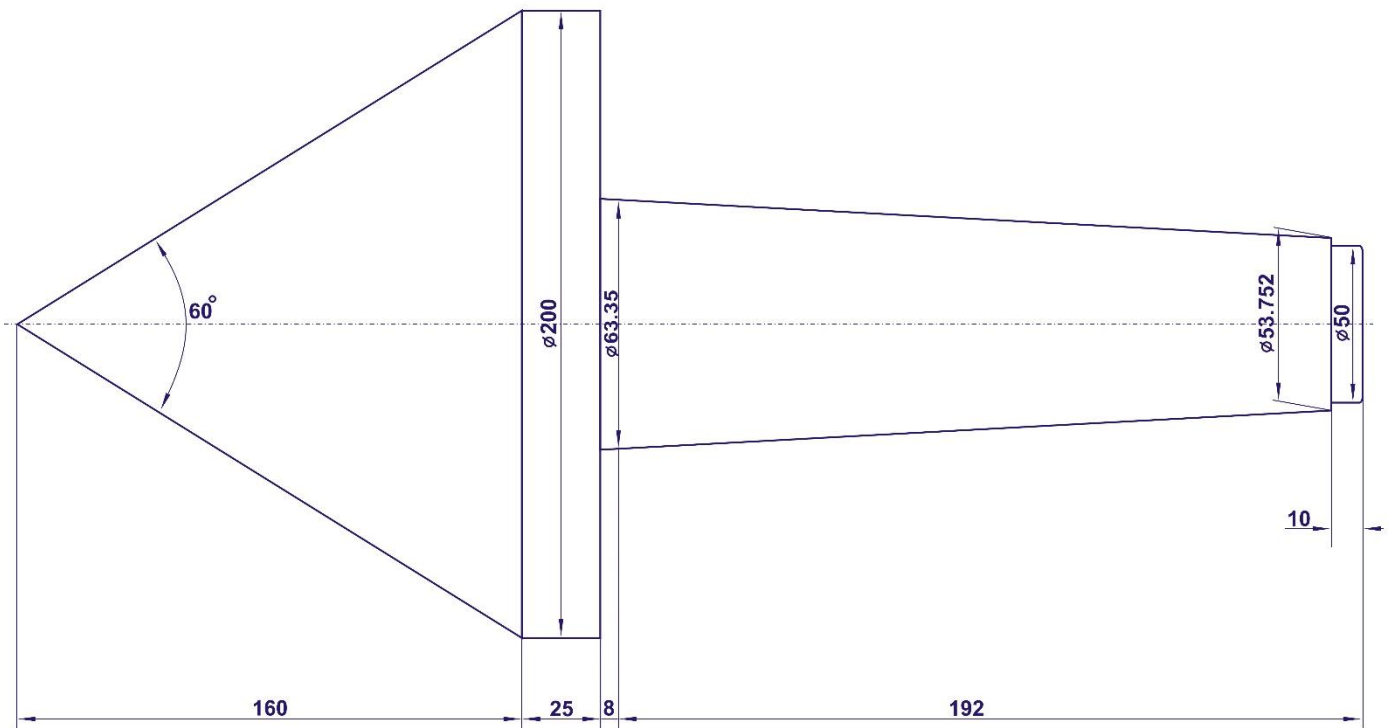
Appendix – III to Annexure "A"**DEAD CENTRE**

Note: Run - Out of Centre Ground Shall not Exceed 0.05 mm with respect to Taper

AFFIDAVIT
NO DEFAULTING CERTIFICATE

It is certified that M/s _____ have never been defaulted or blacklisted with any Govt / Semi Govt / Defence Origination within or outside.

(Designation, Signature & Stamp)

(Signature & Stamp of Notary Public)

AFFIDAVIT
NO LITIGATION CERTIFICATE

It is certified that M/s _____ have No litigation history where decision went against the firm anywhere within or outside Pakistan.

OR

It is certified that M/s _____ have following litigation history:-

- a.
- b.
- c.

(Designation, Signature & Stamp)

(Signature & Stamp of Notary Public)