

SURVEY OF PAKISTAN
DIRECTORATE OF PRINTING & GEODESY
Rawalpindi

INVITATION TO BID
Procurement of Bench Mark Markers

Survey of Pakistan (SoP), invites electronic bids for the procurement of Bench Mark Markers through EPADS under the Project titled “**ESTABLISHMENT OF NEW GENERATION NATIONAL GEODETIC DATUM OF PAKISTAN (Datum Project)**”. The manufacturers/ suppliers / contractors etc., who are active taxpayers with valid GST, NTN can apply for supply of these items.

S. No.	Item	Qty.
1	Bench Mark Markers with engraved title on top (stainless steel aesthetic grade 304)	1000

Bidding document, containing detailed terms and conditions, can be downloaded by the interested bidders from PPRA’s website, EPADS www.eprocure.gov.pk and SoP’s website www.sop.gov.pk.

The bids, prepared in accordance with the instructions in the bidding documents, must be uploaded on PPRA EPADS, and original Bank draft (earnest money) must reach Survey of Pakistan, Faizabad, Murree Road, Rawalpindi duly addressed to the “Chairman Purchase Committee, Datum Project, on or before **13-01-2025 at 11:00 hrs.** Bids will be opened on the same day at **11:30 hrs.**

(MUHAMMAD AQIB)
DEPUTY DIRECTOR
CHAIRMAN PURCHASE COMMITTEE
DATUM PROJECT
051-9290241

TERMS & CONDITIONS

1. Technical & Financial Bids should be submitted through PPRA EPADS on or before **11:00 hours on 13-01-2025**. These will be opened at **11:30 hours** on the same day in the presence of bidders or their authorized representatives.

2. The detail of material for Bench Mark Markers with engraved title on top (Stainless steel aesthetic grade 304) is given below. The design of Bench Mark Markers is shown in figures given in this document below.

S. No.	Item	Qty.	Design
<u>Bench Mark Markers</u>			
1.	Bench Mark Markers with engraved title on top (stainless steel aesthetic grade 304)	1000	Sketch-1 Sketch-2 Sketch-3

1. The sketches shown in this document are for general overview, the bidders are strictly bound to visit the SoP Headquarters, Survey of Pakistan, Rawalpindi for accurate measurements of sample of Bench Mark Markers dimension.
2. The Bench Mark Markers supplied shall be verified by Technical Committee/Chinese's resident experts in accordance with the sample and in case of any discrepancies the firm shall be responsible for rectification on its own expenses.
3. Material grade should be as per sample.
4. The samples are available in office of No. 6 Geodetic unit, SoP Faizabad, Rawalpindi which can be seen by the bidders before bidding. All the Bench Mark Markers are required exactly as per sample.
5. In order to assess the capability of firm/bidder, the firm will have to provide one sample of Bench Mark Markers as mentioned in technical evaluation criteria below in this document.
6. The method of procurement is **Single stage – two envelopes** as per PPRA's rules.
7. Only registered suppliers who are on Active Tax Payers List (ATL) of FBR are eligible to participate in the bidding process. The supplier should attach a proof that he is on ATL of FBR Data Base.
8. After the **evaluation & recommendations by the concerned Technical Evaluation/Quality Control Committee**, Financial Proposals of only technically qualified bids will be opened. Date and time of opening of Financial Proposal will be informed to bidders after evaluation of technical bids by the Committee.

9. The Financial Proposals of technically non-qualified firms shall not be opened.
10. **Rs. 200,000/- earnest** money in shape of pay order/bank draft in the name of Chairman Purchase Committee, **Datum Project**, Survey of Pakistan, Rawalpindi enclosed in the envelope should be submitted to Chairman Purchase Committee on or before date of Opening of bids.
11. Bidder will provide compliance sheet of BM Markers against specifications. Bidder response should be explicit for each component. Any ambiguous and implicit words in quotations (such as yes, ok, offered, available, provided, etc.) will be treated as 'non-responsive'.
12. Bidder shall not submit any document after due date except in response to any clarification sought by Project Director and in response to clarifications no change shall be made.
13. **Survey of Pakistan reserves the right to reject any or all bids or accept any bid subject to the relevant provisions of PPRA Rules-33.**
14. **Quantity of items can be increased or decreased as per requirement.**
15. Only registered suppliers who are on Active Tax Payers List (ATL) of FBR are eligible to participate in the bidding process. The supplier should attach a proof that he is on ATL of FBR Data Base.
16. In Financial Proposal, the prices should be inclusive of all leviable taxes. The bidders should also provide the detail price analysis of the items in their Financial Proposal along with net quoted unit rate with GST and without GST showing complete pen picture of their quoted prices. Prices should be mentioned both in words & figures. In case of difference, the amount given in words will be accepted.
17. Bids will be valid for 120 days from the date of opening of bid.
18. Successful bidder(s) will deliver the items at **HQs, Survey of Pakistan, Faizabad, Murree Road, Rawalpindi at their own cost/ freight.**
19. Successful bidder(s) will be required to execute agreement governing the terms & conditions of the contract.
20. **Liquidation Damages:** The firm has to pay liquidation damages for the period of delays in supply of deliverables up to rate of 2% of the contract price per month or part of a month exceeding the original delivery period subject to the provision that total liquidation damages thus levied will not exceed 10% of the total contract price.
21. **Performance Guarantee:** The bidder shall provide to Survey of Pakistan (SoP), a Performance Guarantee having a value of 10% of the contract price and which is valid for 06 months beyond the expected date of delivery of the items. Performance Guarantee shall be submitted just after successful submission of deliverables and after obtaining Acceptance letter from SoP. 10% performance guarantee will remain held with SoP and be released after 60 days of supply of items..
 - a. Bank Guarantee furnished against this contract is un-conditional and encashable at the will of the firm. Firm will undertake not to hinder/restrain its encashment through court, extra judicial or any other way (including administrative process)

- b. If the firm fails to produce the Bank Guarantee within specified period, SoP reserves the right of cancelling the contract at the risk and expense of the firm. In the event of un-satisfactory performance or of any breach of terms of the contract, the bank guarantee shall be forfeited to the govt at the discretion of the firm.
22. **Confidentiality:** The firm shall not, during the process of execution or after expiration of this contract, disclose any proprietary or data without the prior written consent of SoP.
23. **Force Majeure:** Both the parties shall not be held responsible for any delay occurring in the Project due to event of Force Majeure such as acts of God, War, Civil commotion, Strike, Lockouts, Act of Foreign Govt and its agencies and disturbance directly affecting the parties over the events or circumstances where both the parties have no control. In such an event both parties will inform each other within 15 days of the happening and within the same timeframe about the discontinuation of such circumstances / happening in writing.
24. Any firm, which furnishes wrong information, will be liable for legal proceeding. Any contract awarded in such case when find out, will be cancelled.
25. The bidder/lead should not be blacklisted by any of its clients. An affidavit to this affect must be submitted by the bidder.
26. **Litigation:** In case any dispute, only court of law at Islamabad/ Rawalpindi have jurisdiction to decide the matter.
27. For more information and sample view, please contact Mr. Muhammad Aqib, Chairman Purchase Committee at telephone No. 051-9290241 or Mr. Muhammad Hassan (0312-5117452) during office hours.

EVALUATION CRITERIA

1. **Technical Evaluation:** Technical Evaluation Reports of the Technical Proposals will be made as per tender specifications without the reference to the price as per PPRA Rule 36 (b)(v). In order to assess the capability of firm/bidder, the firm will have to provide samples of three items as mentioned below. The Technical proposal evaluation committee will evaluate the technical proposals and qualifications. Evaluation Criteria for Technical Evaluation is as under. Non-Compliance of any of following criteria will be declared technically non-responsive and disqualified technically.
- a. 100% Compliance of each sub-item of Tender Specifications as mentioned in Form-A
 - b. Availability of certificate Active Tax Payer for-Income Tax & Sales Tax
 - c. Certificate that the firm is not blacklisted by any of its clients.
 - d. Submission one sample of following item on or before date of opening of tender.
 - **Bench Mark Markers with engraved title on top(stainless steel aesthetic grade 304)**

2. Evaluation of Financial Proposals / Bids

- a. Only the Financial Proposals of those bidders will be opened publicly who's Technical Proposals are qualified/ accepted by the Technical Evaluation Committee. **For financial evaluation, the total cost of BM Markers inclusive of taxes indicated in the Financial Proposal will be considered.**
- b. The bid having **the lowest total cost of the BM Markers inclusive of all taxes will be considered as most advantageous bid.**

RESPONSIBILITY AGAINST DAMAGES/OWNERSHIP

The bidder shall be responsible for whole/any damage caused to the item(s) by accident / improper handling / loading, un-loading, before handing over to / taking charge by Survey of Pakistan (SoP). The bidder shall replace the same at its own cost.

PAYMENT:

- i. Payment shall not be made in advance and against partial deliveries.
- ii. The bidder shall provide necessary and supporting documents along with invoice.
- iii. The SoP will undergo verification of the specifications and details of the delivered items. Payment will be rendered upon the full receipt of items and subsequent issuance of a satisfactory certificate by the relevant Technical Evaluation Committee. In the event that the Supplier provides materials of substandard quality, said materials will not be accepted and shall be returned to the Supplier. The Supplier will be held responsible for the entire cost associated with the delivery in such instances.
- iv. SoP shall make payment for items supplied provided to the bidder as per Govt. policy in Pak Rupees through crossed Cheque.
- v. All payment shall be subject to any and all taxes, duties and levies applicable under the laws of Pakistan for the whole period starting from issuance of Supply Order till delivery of the items.

SUPPLY PERIOD:

- i. The firm will provide items within a period of 20 days of the tender.
- ii. The most advantageous bidding firm for BM Markers shall be responsible to deliver goods at **Survey of Pakistan, Faizabad, Murree Road, Rawalpindi at their own cost/ freight** within due time as given in Supply Order/Tender document.

AGREEMENT DEED

After receiving work order/supply order, the firm has to sign a formal agreement deed on a stamp paper of appropriate value as per attached sample.

CONTRACT AGREEMENT

GOVERNMENT OF PAKSITAN
(MINISTRY OF DEFENCE)
SURVEY OF PAKISTAN
RAWALPINDI

Contract No. /11-A-25/Datum Tender, dated: - -2024
Refers Supplier's Tender No.

An agreement made the _____ day of ----- Two Thousand Twenty Four between the President of Pakistan (herein after called the "PURCHASER" on the one part and M/s. -----, "SUPPLIER" on the other part.

Whereby it is agreed that the Purchaser shall purchase and the Supplier shall sell the stores as described in the schedule given hereunder at the price mentioned therein already transmitted through letter of intent subject to the special conditions as follow:

SUPPLY SCHEDULE

Description of BM Markers	Qty/ (Units)	Rate per unit including taxes (Rs.)	Total Cost including taxes (Rs.)	Delivery Date
				On or before
Total:				

WARNING: Any information about the sale/purchase of the stores under this contract shall not be communicated to any person, other than the manufacturer of the stores or to any press or agency not authorized by the Surveyor General of Pakistan/Ministry of Defence to receive it. The breach of the undertaking shall be punishable under the Official Secrets Act, 1923

CONTRACT CONDITIONS/CLAUSES:

- 1). **Name of consignee:** **Project Director, Datum Project, Survey of Pakistan Rawalpindi.**
- 2). **Supplier's Name and Address:** M/s.
- 3). **Supplier's NTN No.**
- 4). **Supplier's Sales Tax Reg. No:**
- 5). **Date of Delivery:**
- 6). **Dispatch Instructions:** The BM Markers will be delivered to the consignee under firm's own arrangements. Supplier will ensure safe delivery of items at SoP Faizabad Rawalpindi without any loss or damaging.
- 7). **Safe Delivery of Goods**
- 8). **Inspection:**
 - a) Inspection Authority: **Technical Evaluation Committees (TECs)**
 - b) Inspection Officer: **Chairman Technical Evaluation Committees**
 - c) Place of Inspection: **Consignee's Premises at Survey of Pakistan, Faizabad, Murree Road, Rawalpindi at their own cost/ freight.**
 - d) The Inspecting Officer will be informed 02 working days in advance about the time for inspection
- 9). **Checking of Stores at Consignee's End:** All stores will be checked at consignee's premises in the presence of supplier's representatives. If, for the reasons of economy or other the supplier decides not to nominate his representative for such checking, then advance written notice to this effect will be given by the supplier to the **Project Director, Datum Project, Survey of Pakistan Rawalpindi** under intimation to **CPC** prior to or immediately on delivering stores. In such an event, the supplier will clearly under take the decision of consignee with regard to quantities and description of a consignment, which will be taken as final and if any discrepancy found will according be made up by the supplier.
- 10). **Terms of Payment:**
 - a) 100% payment of value of the stores supplied will be paid to M/s. -----
-----, through Cheque by submission of bills duly supported by the **NOC** from concerned **TEC**
 - b) Bill will be furnished to the Project Director, Datum Project SoP, Rawalpindi.
- 13). **Taxes & Duties:**

- a) **Duties & Taxes Applicable:** The prices quoted are inclusive of all kinds of duties and taxes. The purchaser shall not be liable for reimbursement of duties and taxes on the contracted goods other than those given in the quoted rates. The payment of element of taxes and duties, which are included in quoted rates, will be made to the supplier only after production of duly authenticated documentary proof of its payment to the respective department. In case fresh taxes and duties are levied by the government after opening of the tender will signing of the contract and during the currency of the contract i.e. within the original delivery period) or if the existing rates of taxes are increased after opening of the tender and during the currency of the contract, liability shall be of the purchaser and the same shall be reimbursed to the supplier at actual, on production of documentary proof of his payment duly authenticated. In case of any subsequent decrease in existing or future duty or taxes by the Govt. after opening of tender and during the currency of the contract the liability shall be of the supplier and the supplier shall reimburse the same to SoP.
- b) For release of payment, the supplier would be required to furnish the following documents to **Project Director**.
- i Proof of registration with Sales Tax Department (Copy of Registration Certificate).
 - ii Sales Tax Invoice in original showing description/quantity/value of good and current amount of Sales Tax leviable thereon.

14). **Bank Guarantee Clause:**

- a) To ensure timely and correct supply of stores and smooth execution of warrantee conditions the firm will furnish a bank guarantee/draft from a schedule bank for an amount of 5% of the total value of the contracted stores amounting to Rs. ----- to **CPC**. After completion of warrantee period i.e. 01 month from the date of signing of NOC by **PC** the supplier will request the **CPC** through **Project Director** for the withdrawal of bank guarantee/draft. The bank draft will be encased/deposited in SoP's bank account. The bank draft shall be produced by the supplier within 07 days from the date of issue of letter of intent/signing of contract deed and shall remain in force till completion of the warrantee period beyond the date of inspection.
- b) If the supplier fails to produce the bank guarantee/draft within the specified period, the Project Director reserves the right of canceling the contract at the risk and expense of the supplier. In the event of un-satisfactory performance or of any breach of terms of the contract, the bank guarantee/draft shall be forfeited to the government at the discretion of the purchaser. On satisfactory performance of the contract the bank guarantee/draft will be returned to the supplier by CPC, on receipt of clearance from the Consignee.
- c) Bank guarantee/draft furnished against this contract is un-conditional and en-cashable at the will of purchaser. Supplier undertakes not to

hinder/restrain its encashment through court, extra judicial or any other way (including administrative process).

15). **Supplier Warranty/Guarantee:**

- a) The supplier shall furnish warranty for the stores under supply against defects in material workmanship, and satisfactory performance for one month. The stores will be of the high-test grade and consistent with general expectable standard for the stores of type ordered in full conformity with governing specifications and performance of stores with the liability of replacing defective/unacceptable part free of cost within **07 days** by the supplier on receiving the discrepancy report, failing which the purchaser shall have the right to purchase the stores (against the stores declared defective) at the supplier's risk and expense. The supplier also undertakes to make good the deficiency in supply, if any.
- b) Supplier's warranty shall be provided to the consignee along with the store.

16). **Inspection after Expiry of Delivery Period:** Unless informed and directed to the contrary during the currency of the contract, the Inspection Officer will continue the inspection of the stores at firm's risk even after expiry of delivery period. Such acceptance will not prejudice the purchaser's right to cancel the contract or to extend the delivery period with or without liquidated damages.

17). **Failure and Termination:** Should the supplier fail to deliver the stores within stipulated period of supply, on the expiry; the purchaser shall be entitled at his option to take either of the following actions:

- a) To cancel the contract or purchase from elsewhere the stores not delivered, at risk and expense of the supplier and without notice to him. The supplier shall also be liable to any loss which purchaser sustains on this account but shall not be entitled to any gain of repurchase.
- b) To make the supplier pay liquidation damages for the period of delays in supply up to the rate of **2%** of the contract value un-supplied stores per month or part of a month for the period exceeding the original delivery period subject to the provision that total liquidation damages thus levied will not exceed **10%** of the total contract value.
- c) If contract of the firm is cancelled at 'Risk and Expense' then the latest equivalent of their cancelled stores will be purchased at 'Risk and Expense' of the concerned firm if the cancelled type/category is not available in the market. Similarly, an item of contract on FOR (indigenous) basis may be produced at risk and expenses of the firm on FOR (Imported) basis and vice-versa in the interest of the state.

- 18). **Force Majeure:** Force Majeure shall mean any event, act or other circumstances, not being an event, act or circumstance, under the control of the purchaser or of the supplier. Non-availability of raw material from the manufacturer of stores, or of export permit for the export of the contracted stores from the country of its origin, shall not constitute Force Majeure.
- 19). **Special Instructions:**
Warranty/Guarantee:
- a) **The items supplied by the firm will be utilized for the construction of BMs throughout the country.** The technical committee will supervise the quality of material during the construction. If any discrepancy is found, the supplier will be liable to replace the item at its own cost. The supplier shall replace the defective stores free of cost. Warranty/Guarantee Certificate with regards to all items being supplied would be provided to the consignee along-with the stores.
 - b) Trade mark of all items should be quoted clearly. On receipt, if any stores are found to be otherwise it will be changed/ replaced free of cost.
 - c) The Supplier will be strictly bound to supply the contracted stores as per tendered specifications, and fulfill all responsibilities in this regard.
- 20). **Litigation:** In case of any dispute, only court of jurisdiction at Rawalpindi shall have the jurisdiction to decide the matter.

SIGNATURES

PURCHASER

Designation	Project Director
Name	
Signature	
For and on behalf of the President of Islamic Republic of Pakistan.	

SUPPLIER

Name	
Designation	
Signature	

TECHNICAL SPECIFICATIONS

S. No.	Item	Qty.	Design
<u>Bench Mark Markers</u>			
1.	Bench Mark Markers with engraved title on top (stainless steel aesthetic grade 304)	1000	Sketch-1 Sketch-2 Sketch-3

Note:

- The sketches shown in this document are for general overview, the bidders are strictly bound to visit the SoP Headquarters, Survey of Pakistan, Rawalpindi for accurate measurements of Bench Mark Markers dimension.
- The Bench Mark Markers supplied shall be verified with the sample and in case of any discrepancies the firm shall be responsible for rectification of error on their own expenses.
- Material grade should be as per sample.

Design Specifications

1. Bench Mark Markers

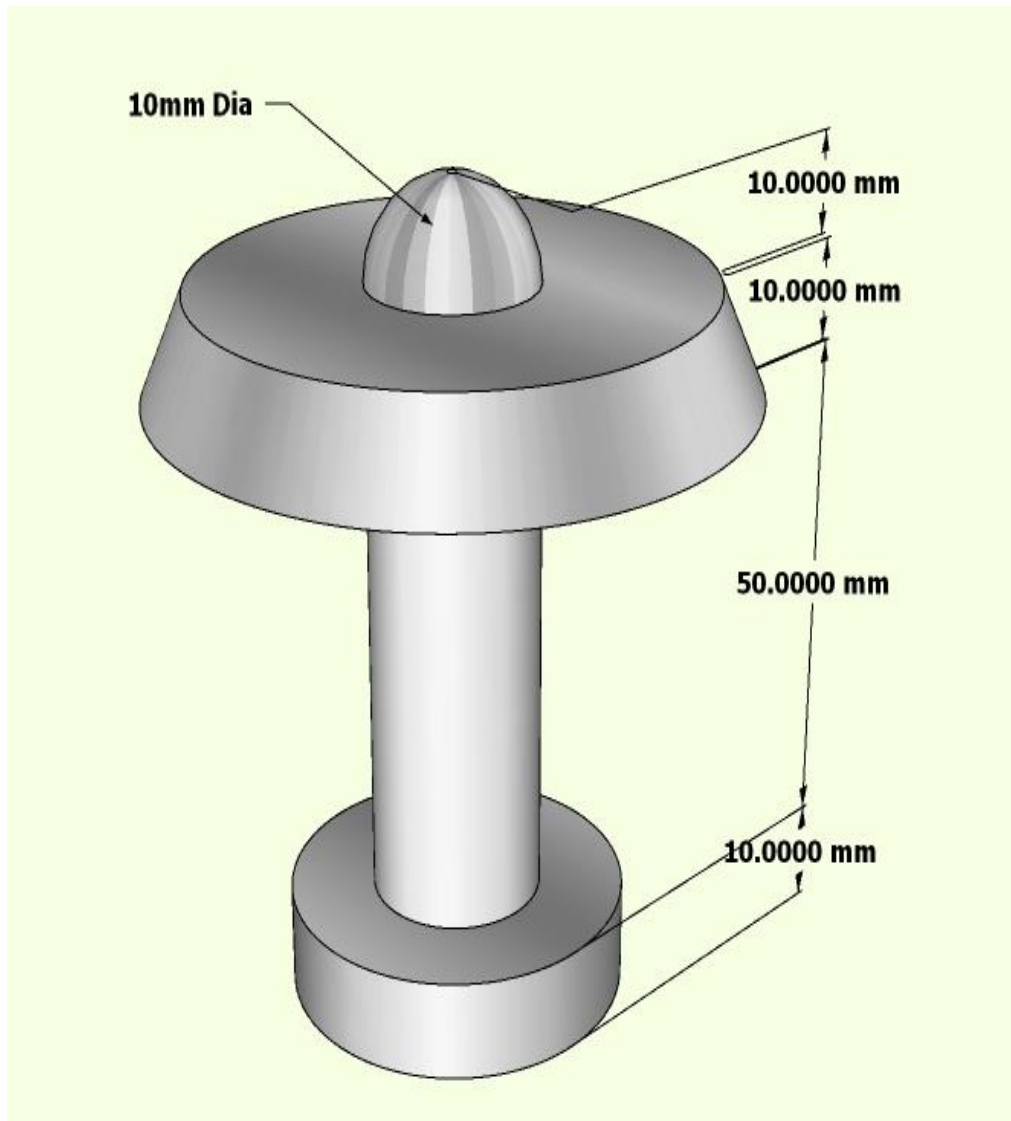

Sketch-1

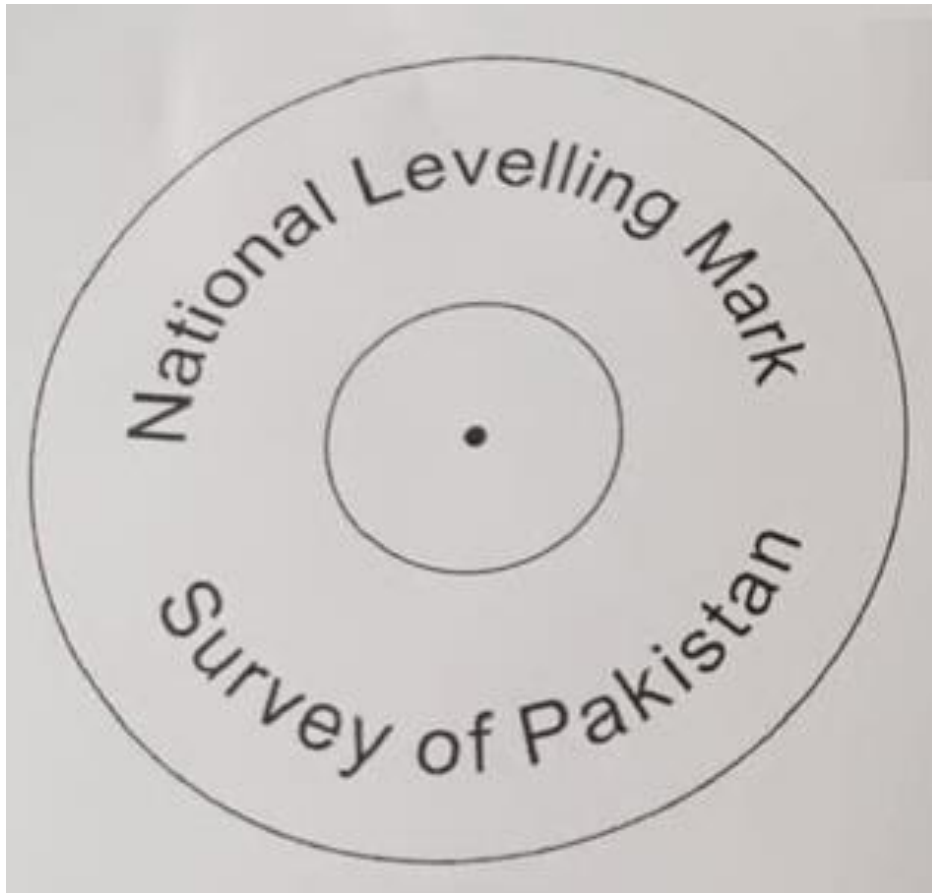

The Bench Mark Marker includes the engraved title as “National Levelling Mark Survey of Pakistan” on the top as per design shown below.

Sketch-2

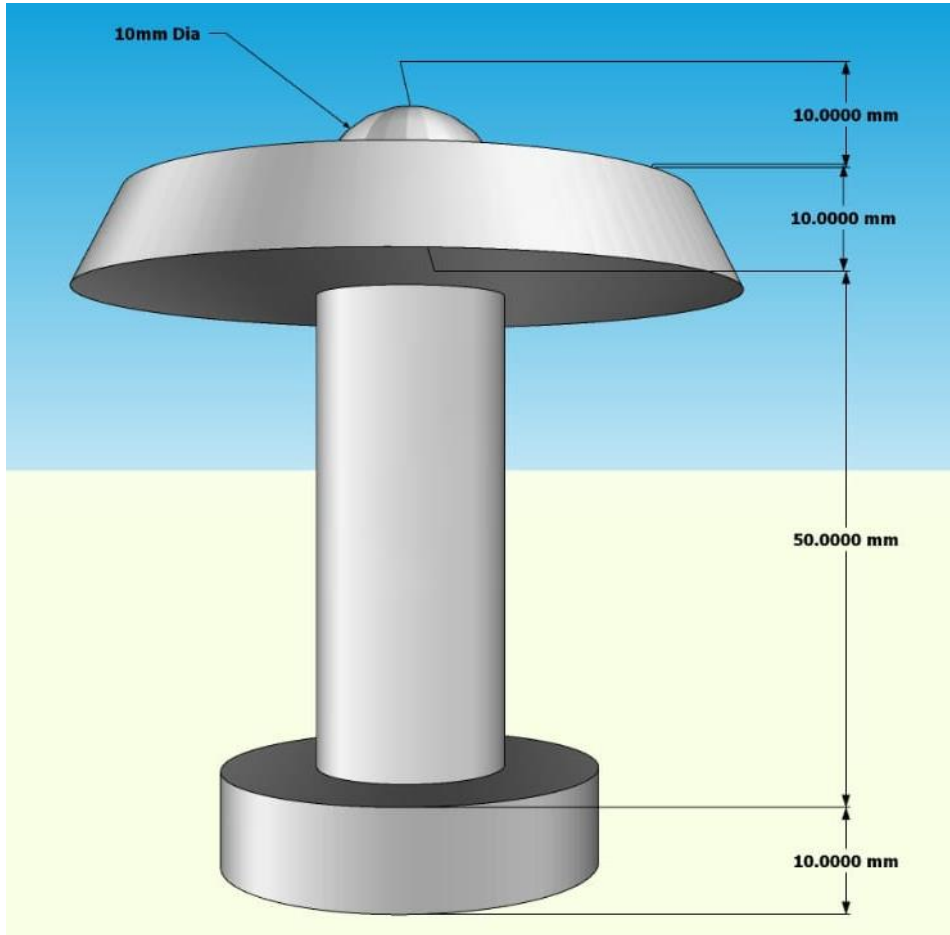

Sketch-3

Note: All participating bidders are required to visit No. 6 Geodetic unit, SoP HQs, Rawalpindi to see samples of above BM Markers before bidding. All the Bench Mark Markers are required exactly as per sample available in No. 6 Geodetic unit.

TECHNICAL PROPOSAL

S. No.	Item	Compliance
1	Bench Mark Markers with engraved title on the top	
2	Mass of one marker 0.5 Kg	
3	Material stainless steel aesthetic grade 304	
4	Provision of one Piece of BM Marker as sample	

It is certified that the BM Markers **material/ items** mentioned above table will be provided as per specimen design attached in the tender document along with technical specifications.

**AUTHORISED SIGNATURE
NAME & SEAL OF FIRM/SUPPLIER**

FINANCIAL PROPOSAL**Procurement of Bench Marks Markers**

S. No.	Item	Unit Price (Rs.)	GST @ (Rs.)	Unit Price including GST	Quantity	Total Amount (including GST) (Rs.)
1	Bench Mark Markers with engraved title on top (stainless steel aesthetic grade 304)				1000	

**AUTHORISED SIGNATURE
NAME & SEAL OF FIRM/SUPPLIER**