

ATTACHMENT - I

(See regulation 2)

**PUBLIC PROCUREMENT REGULATORY  
AUTHORITY (PPRA)**

**CONTRACT AWARD PROFORMA – I**

To Be Filled And Uploaded on PPRA Website In Respect of All  
Public Contracts of Works, Services and Goods Worth Fifty  
Million or More

- NAME OF THE ORGANIZATION/DEPTT. Sui Northern Gas Pipelines Ltd.
- FEDERAL / PROVINCIAL GOVT. Public Sector Organization
- TITLE OF CONTRACT HO/M/005/23
- TENDER NUMBER LE-001/23
- BRIEF DESCRIPTION OF CONTRACT Sensing Material
- TENDER VALUE Rs. 2,083,100/- Excl. GST
- ENGINEER'S ESTIMATE Rs. 2,083,100/- Approx. Excl. GST
- ESTIMATED COMPLETION PERIOD 90 Days
- WHETHER THE PROCUREMENT WAS INCLUDED IN ANNUAL PROCUREMENT PLAN? Yes / No
- ADVERTISEMENT :
  - (i) PPRA Website 26.01.2023 (TS500019E) Yes / No (Federal Agencies) (If yes give date and PPRA's tender number)
  - (ii) News Papers NO (If yes give names of newspapers and dates)
- TENDER OPENED ON (DATE & TIME) 13.02.2023 1600 HRS
- NATURE OF PURCHASE \_\_\_\_\_ Local / International
- EXTENSION IN DUE DATE (If any) \_\_\_\_\_ Yes / No

10 sub 1244 . 0 5284

- NUMBER OF TENDER DOCUMENTS SOLD (02)  
(Attach list of Buyers)
- WHETHER QUALIFICATION CRITERIA WAS INCLUDED IN BIDDING/TENDER DOCUMENTS \_\_\_\_\_ Yes / No  
(If yes enclose a copy).
- WHETHER BID EVALUATION CRITERIA WAS INCLUDED IN BIDDING/TENDER DOCUMENTS \_\_\_\_\_ Yes / No  
(If yes enclose a copy).
- WHICH METHOD OF PROCUREMENT WAS USED: - (Tick one)
  - a) SINGLE STAGE – ONE ENVELOPE PROCEDURE
  - b) SINGLE STAGE - TWO ENVELOPE PROCEDURE \_\_\_\_\_
  - b) TWO STAGE BIDDING PROCEDURE. \_\_\_\_\_
  - c) TWO STAGE – TWO ENVELOPE BIDDING PROCEDURE. \_\_\_\_\_
- PLEASE SPECIFY IF ANY OTHER METHOD OF PROCUREMENT WAS ADOPTED WITH BRIEF REASONS (i.e EMERGENCY, DIRECT CONTRACTING, NEGOTIATED TENDERING ETC.) N.A
- WHO IS THE APPROVING AUTHORITY General Manager(Procurement)
- WHETHER APPROVAL OF COMPETENT AUTHORITY WAS OBTAINED FOR USING A METHOD OTHER THAN OPEN COMPETITIVE BIDDING. N.A
- NUMBER OF BIDS RECEIVED 01
- WHETHER THE SUCCESSFUL BIDDER WAS LOWEST BIDDER Yes / No
- WHETHER INTEGRITY PACT WAS SIGNED \_\_\_\_\_ Yes / No

2

**PUBLIC PROCUREMENT REGULATORY**  
**AUTHORITY (PPRA)**

**CONTRACT AWARD PROFORMA – II**

To Be Filled And Uploaded on PPRA Website In Respect of All  
Public Contracts of Works, Services & Goods Worth Fifty  
Million Rupees or More

- NUMBER OF BIDDERS PRESENT AT THE TIME OF OPENING OF BIDS  
Nil
  
- NAME AND ADDRESS OF THE SUCCESSFUL BIDDER M/s.Connexion  
International, 3-B, Haroom Chambers, Altaf Hussain Road, Karachi
  
- RANKING OF SUCCESSFUL BIDDER IN EVALUATION REPORT  
(i.e. 1<sup>st</sup>, 2<sup>nd</sup>, 3<sup>rd</sup> EVALUATED BID). Single Bidder
  
- NEED ANALYSIS (Why the procurement was necessary?) To Expand the  
network as well as in the interest of GOP  
\_\_\_\_\_  
\_\_\_\_\_
  
- IN CASE EXTENSION WAS MADE IN RESPONSE TIME, WHAT WERE THE  
REASONS (Briefly describe) No.  
\_\_\_\_\_  
\_\_\_\_\_
  
- WHETHER NAMES OF THE BIDDERS AND THEIR PRICES WERE READ  
OUT AT THE TIME OF OPENING OF BIDS \_\_\_\_\_ Yes / No
  
- DATE OF CONTRACT SIGNING 05.04.2023 (Copies enclosed)  
(Attach a copy of agreement)
  
- CONTRACT AWARD PRICE Rs.1,545,847/- Incl. GST

2

➤ WHETHER COPY OF EVALUATION REPORT GIVEN TO ALL BIDDERS \_\_\_\_\_ **Yes / No**  
(Attach copy of the bid evaluation report)

➤ ANY COMPLAINTS RECEIVED \_\_\_\_\_ **Yes / No**  
(If yes result thereof)  
\_\_\_\_\_  
\_\_\_\_\_

➤ ANY DEVIATION FROM SPECIFICATIONS GIVEN IN THE TENDER NOTICE/DOCUMENTS \_\_\_\_\_ **Yes / No**  
(If yes give details)

➤ DEVIATION FROM QUALIFICATION CRITERIA \_\_\_\_\_ **Yes / No**  
(If yes give details)  
\_\_\_\_\_  
\_\_\_\_\_

➤ SPECIAL CONDITIONS, IF Any  
(Give Brief Description)  
**Nil**  
\_\_\_\_\_  
\_\_\_\_\_

2

**SUI NORTHERN GAS PIPELINES LTD.**

GAS HOUSE, 21-KASHMIR ROAD, LAHORE.

**LOCAL PURCHASE ORDER NO: HO/M/005/23**

Date: 01.03.2023

**Net Cost Rs. 1,545,847/-**

**M/s. Connexion International,**  
 3-B, Haroon Chambers, Altaf Hussain Road,  
 Karachi:

ORDER DESPATCHED ON 05/02/23

Subject: Sensing Material.

Reference: Your Quotation # 904 dated Nil in response to our tender enquiry # LE-001/23 dated 05.01.2023. Your STRN # 32-77-8762-963-22, NTN # 8724943-2. Our Sales Tax Reg. # 03-91-9999-967-19.

Dear Sirs,

We are pleased to place an order on you for the following items, subject to terms and conditions printed overleaf, changes, additions, thereto, including those to the ordered material will be authorized solely by an amendment to this order which will be executed in the same manner as this order.

Sr. #.	DESCRIPTION.	Unit.	Qty.	Rate (Rs.)	Total Value (Rs.)
1.	<u>Equalizing Pad Assembly-3-Way Valve Assy.</u> Size: 1/2" 3-Way Valve Assy NPT (FM) Part # HLS3DBB, Make Parker, Origin: USA	Nos.	20	36,000/-	720,000.00
2.	<u>S.S. Tube</u> Dia 3/8"(0.035WT) SS 316L, Make Sandvik, Origin: Sweden	Mtrs.	72	1,176/-	84,672.00
3.	<u>S.S. Tube</u> Dia 1/2" SS 316L, Make Sandvik, Origin: Sweden	Mtrs.	72	1,399/-	100,728.00
4.	<u>Tubing Clamp</u> Size: Dia 1", Make Parker, Origin: USA	Nos.	40	1050/-	42,000.00
5.	<u>Tubing Clamp</u> Size: Dia 3/4", Make Parker, Origin: USA	Nos.	40	950/-	38,000.00
6.	<u>Tubing Clamp</u> Size: Dia 3/8", Make Parker, Origin: USA	Nos.	40	450/-	18,000.00
7.	<u>Tubing Clamp</u> Size: Dia 1/2", Make Parker, Origin: USA	Nos.	40	660/-	26,400.00
8.	<u>SS Connector</u> 3/8"T x 1/2"P (Male),Part # 6MSC8N,Make Parker, Origin: USA	Nos.	40	1,495/-	59,800.00
9.	<u>Male Connector</u> 3/8"T x 1/4"P (Male),Part # 6MSC4N,Make Parker, Origin: USA	Nos.	40	1,235/-	49,400.00
10.	<u>Male Connector</u> 1/2"T x 1/2"P (Male),Part # 8MSC8N,Make Parker, Origin: USA	Nos.	40	1,526/-	61,040.00
11.	<u>Union Connector</u> 3/8"T x 3/8"T, Part # 6SC6, Make Parker, Origin: USA	Nos.	18	1,495/-	26,910.00
12.	<u>SS Equal Tee</u> 1/2"T, Part # 8ET8, Make Parker, Origin: USA	Nos.	10	4,809/-	48,090.00
13.	<u>SS Equal Tee</u> 3/8"T, Part # 6ET6, Make Parker, Origin: USA	Nos.	10	3,500/-	35,000.00
				<b>Total:</b>	<b>1,310,040.00</b>
Plus Sales Tax @ 18%					235,807.20
Total F.O.R Multan Store Price including Sales Tax @18%.					<b>1,545,847.20</b>
				(Say Rs.)	<b>1,545,847.00</b>
Notes mentioned on attached Annexure-I would be applicable to this purchase order.		Rupees: One Million Five Hundred Forty Five Thousand Eight Hundred Forty Seven only).			

Yours Faithfully,  
 SUI NORTHERN GAS PIPELINES LIMITED

(FIAZ RASOOL)

DY. CHIEF OFFICER (PROCUREMENT)  
 for MANAGING DIRECTOR

GM (Procurement)

App. ER  
 10/1/23

Indentor : Sr. Engg. Comp, Multan (T)	Indent # MUL/C/LP/0050/23 Dated 06.09.2022.
A/C : Store Stock (Index # 35.031.747.3, 26.002.435.3, 26.002.436.3, 35.031.947.3, 35.031.946.3, 35.031.944.3, 35.031.943.3, 35.031.833.3, 35.031.813.3, 26.018.178.3, 35.031.826.3, 35.031.883.3 & 35.031.884.3).	PCS # 001 dated 05.01.2023. Technical vetting received vide GM(Comp), Multan memo # C-48/M(07) dated 23.02.2023.
Management Sanction Ref: TR/Comp/008-22	Dated: 12.05.2022. Rs. 10.052 million.

1. GM(Account) copy  
 2. Store Office copy  
 3. GM (PT)'s copy

4. Material Receiving Store Copy  
 5. Indentor's copy  
 6. Inventory Section (Acct. H.O.) copy

**SUI NORTHERN GAS PIPELINES LIMITED**

**ANNEXURE-I**

**PURCHASE ORDER NO.HO/M/005/2023**

**1. PERFORMANCE/WARRANTY BOND GUARANTEE**

Please arrange to provide at your own cost a Performance/Warranty Bond Guarantee equivalent to 10% of the total value of the purchase order (**excluding sales tax**) within 30-days after receipt of purchase order as per clause 11 of the tender enquiry. The Performance/Warranty Bond should remain valid for six months after the last portion of the goods have been delivered to the final destination. In case Performance/Warranty Bond Guarantee is not received within given time period of 30 days, the validity period of 06 months will be increased to 09 months after the last portion of the goods and services are delivered to the final destination.

**2. DELIVERY**

Material should be supplied as per our specification. Sub-standard/defective will have to be replaced by you on 'NO CHARGE BASIS' even after our acceptance.

You will deliver the material within **90 days** from the date of receipt of purchase order at our Transmission Stores, Piran Ghaib Road, Multan.

**3. INSPECTION**

Inspection of material will be undertaken at our premises.

**4. PAYMENT**

Payment will be made to you by our Accounts Department within 30 days after satisfactory completion of delivery as given in purchase order and after receipt of your bills in duplicate supported with all requisite documents including receipted copies of Delivery Challan.

**5. SALES TAX**

Above prices are inclusive of all Government Taxes and duties, including Sales Tax @ 18%. Sales tax will be paid/deduct as per law upon submission of documentary evidence.

**6. WARRANTY**

Warranty period one year from the date of delivery of material.

**7. LATE DELIVERY CHARGES**

If the material as given in the order have not been delivered on time and as per stipulations in the contract except on account of Force Majeure within the delivery period given in the contract, Sui Northern Gas Pipelines Limited shall be entitled to recover 1% (one percent) of the total value (excluding sales tax) of the delayed part of material for each week of delay, by way of Late Delivery Charges subject to maximum of 10% of the total value (excluding sales tax) of the delayed part of the material. The period for calculation of Late Delivery Charges shall be reckoned in number of days for which the material was delayed.

All the supplies after expiry of scheduled delivery period will be subject to clause mentioned above and does not require any additional noting/marking/comments on delivery challans etc. at the time of receipt of delayed supplies.

The payment of such Late Delivery Charges shall not relieve the supplier from performing and fulfilling its obligations under the contract nor will the corresponding rights and entitlements of Sui Northern be affected or reduced in any manner.

Whenever Late Delivery Charges or any other claim become payable, Sui Northern Gas Pipelines Limited, in its sole discretion shall quantify the same as per tender terms and serve a written notice upon the supplier requiring immediate payment thereof. If the supplier fails to remit payment within the given time period as mentioned in the notice, to be served under any mode of communication i.e E-mail, Fax, Courier, registered postal cover etc., SNGPL will become entitled to recover the same forthwith by calling upon the complete Performance/Warranty Bond Guarantee. The amount over and above the SNGPL's claim will be returned to the bank, on supplier's account, after completion of contract performance period.

In case of a contract on turnkey basis or the material covered in the contract is a compact unit consisting of more than one item(s) / part(s) or the delayed part of supply / services, in any way, affects the overall completion, utilization or functionality of the whole item/work, the Late Delivery Charges will be worked out on whole unit(s).

Please also note that all other terms/conditions of our tender enquiry No.LE-001/2023 and those which have been agreed to through exchange of correspondence after bid opening date are integral part of this purchase order.

  
Yours faithfully,  
SUI NORTHERN GAS PIPELINES LIMITED

  
( FIAZ RASOOL )  
DY.CHIEF OFFICER (PROCUREMENT)  
For MANAGING DIRECTOR

  
P.Order No.HO/M/005/2023  
M/s. Connexion International, Lahore  
03/03 14/03/23

SUI NORTHERN GAS PIPELINES LIMITED  
21-KASHMIR ROAD, LAHORE (PAKISTAN)

Phone No. 042-9085060  
Fax No. 042-9201275  
Website: www.sngpl.com.pk

Ref: LE-001/23

Dated: 05.01.2023

M/s OM's Master Traders LHR.  
OM's Construction International, Karachi

**INVITATION TO BID / INSTRUCTIONS TO BIDDERS**  
**SENSING MATERIAL**  
**OUR TENDER ENQUIRY No. LE-001/23**  
**OPENING DATE: 26.01.2023**

Single bid received.  
Tender is extended  
for better competition.

I-A) We enclose one set of our Tender Enquiry for supply of subject noted items comprising of the following: -

- General Terms
  - Schedule of Requirement and Delivery
  - Technical Specifications
  - Price Term Sheet
  - Specimen of Bid Bond
  - Specimen of Performance / Warranty Bond Guarantee
  - Format of Authority Letter for attending public opening of bids (to be provided by the bidders representatives to the bid opening Committee at the time of public opening of technical as well as commercial bids).
  - Questionnaire / Commercial Sheet
  - Certificate Of Full Disclosure And Non-Collusion
  - Manner And Mechanism To Blacklisting / Cross Debarring Of Supplier Or Contractor
- Appendix 'A'  
Appendix 'B'  
Appendix 'C'  
Appendix 'D'  
Appendix 'E'  
Appendix 'F'  
Appendix 'G'  
Appendix 'I'  
Appendix 'J'  
Appendix 'K'

Single bid received  
opened & announced  
in public

Single bid received  
26/1/23

- Your firm and irrevocable offer in Pak Rupees must be based on free delivery at our SNGPL Store Piran Ghaib Road, Multan.
- The delivery must conform to the terms given in the "Schedule of Requirement and Delivery" (Appendix 'B') and must be strictly adhered to. Earlier delivery will also be acceptable.
- General Terms attached as Appendix-A, must be taken into consideration before submitting your quotation.
- Your offer must remain open for a period of **60 days** from the closing date of the tender.
- If you have any doubts as to the meaning of any portion of the specifications or "General Terms", you should when submitting your bid, set out in your covering letter, the interpretation upon which you rely.
- Your offer should be prepared in duplicate and both the copies of your bid/quotation should be addressed and forwarded direct to:-

THE GENERAL MANAGER (PROCUREMENT)  
SUI NORTHERN GAS PIPELINES LIMITED,  
1ST FLOOR, GAS HOUSE, 21-KASHMIR ROAD,  
LAHORE-PAKISTAN.

- Both original and duplicate bids/quotations must be enclosed in duplicate **sealed cover**. Both the **Inner and outer envelope** must marked with the following:-

**"Confidential"**

- Bid / Quotation for the supply of SENSING MATERIAL**
- Tender Enquiry No. LE-001/23**
- Opening date 26.01.2023 Time 1600 Hours**

Sealed cover should not bear any marking which can give any indication about the sender. Offer received by Telex/Telefax/Cable/E-mail will not be accepted.

- Bids/quotations will be received in this office on or before **26.01.2023 by 1530 hours** and will be opened publicly on the same date at **1600 hours** at the address mentioned at Sr.7 above. In case of holiday(s) falling on the date of bids opening bids/quotations will be opened at the same time on the next working day. It will be the responsibility of the bidder to deliver the bids before the closing time. The Company does not take any responsibility, whatsoever, of collection of bids from any agency. Bids/Quotations received after the bids opening date and time will not be considered and will be returned.

New Tender Enquiries



10. *We reserve the right to increase/decrease the quantities or cancel this enquiry in whole or in part before tender opening should our requirement change in the meantime. After tender opening, the quantities may be increased / decreased by 15% of the tender quantities. However, decrease beyond 15% shall be subject to concurrence by the successful bidder.*
11. We also reserve the right to have items 100% inspected by a third party at our own expense, or by our Engineer at your manufacturing premises as well as our Inspection Shop.
12. It must be indicated by the bidders by their offers/quotations that their quotation fully conforms to technical specifications and to the terms and conditions of the tender enquiry.
13. Only one authorized representative of bidder will be allowed to attend the public opening of bids, who will be required to submit an authority letter (as per specimen attached as Appendix 'G') in his favour issued by the respective bidders(s) for attending the public opening of bids, failing which he will not be allowed to attend the public opening.
14. Any attempt to obstruct competition by any means including formation of cartels will lead to rejection of your bid. Furthermore, this may also lead to de-listing for your firm from list of approved /pre-qualified manufacturers of the tendered item.
15. **Reservations / Clarifications, if any w.r.t. tender terms / specifications should be asked by the bidder's 7-days prior to the closing date of the tender.**
16. If needed be, please contact Mr. Fiaz Rasool Dy. Chief Officer (Procurement) Ph: # 042-99085026, E-mail: [fiaz.rasool@sngpl.com.pk](mailto:fiaz.rasool@sngpl.com.pk)
17. It is contractor's responsibility to take measures as per General Procedure of HSE in view of the environmental health, safety law and regulations, which is available at [www.sngpl.com.pk](http://www.sngpl.com.pk).
18. Blacklisting and Debarment of bidders and suppliers shall be as per PPRA Rule No.19.
19. "Bidders are required to submit their firm and irrevocable offer in Pak Rupees inclusive of all Govt. Taxes, Duties & levies etc; except sales tax, which must be based on free delivery at our specified stores/location. The amount of Sales Tax, where applicable, would be mentioned separately. In case GST is not mentioned separately, it shall be considered that offered bid price is inclusive of GST.

However, bidder may be required to provide documentary evidence regarding application or exemption of sales tax as mentioned in bid, if required by us during evaluation of bids or after placement of order/contract. Payment of sales tax shall be made as per prevailing Govt. rules/ regulations."

Yours faithfully,  
SUI NORTHERN GAS PIPELINES LIMITED

(FIAZ RASOOL)  
DY. CHIEF OFFICER (PROCUREMENT)  
for MANAGING DIRECTOR

**Tender Enquiry No. LE-001/23 Due On: 26 .01.2023**

Instrument No. \_\_\_\_\_ Dated \_\_\_\_\_ Amount Rs. \_\_\_\_\_

**SCHEDULE OF REQUIREMENT/DELIVERY  
TENDER ENQUIRY NO. LE-001/23**

The approximate total requirement of **SENSING MATERIAL** and delivery required is as under:-

SR. #.	Description	Qty. Nos.	Bid Bond 2% Valuing Rs.	Delivery Required.
1.	Equalizing Pad Assembly 1/2", 3-Way Valve Assy. NPT (FM)	20	8,000	Free delivery required within 90-days after receipt of purchase order at our SNGPL Stores Piran Ghaib Road, Multan.
2.	SS Tube Dia 3/8" (0.035WT)	72	1,300	
3.	Tubing SS 316L 1/2" <i>sub of MTRs</i>	72	1,600	
4.	Tubing Clamp 1" Dia <i>MTRs</i>	40	900	
5.	Tubing Clamp 3/4" Dia	40	800	
6.	Tubing Clamp 3/8" Dia	40	550	
7.	Tubing Clamp 1/2" Dia	40	700	
8.	SS Connector 3/8" T x 1/2" P (Male)	40	1,000	
9.	Male Connector 3/8" T x 1/4" P CI.-3000	40	750	
10.	Male Connector 1/2" x 1/2" P	40	1,000	
11.	Union Connector 3/8" T x 3/8" T	18	700	
12.	SS Equal Tee 1/2" T	10	800	
13.	SS Equal Tee 3/8" T	10	400	
14.	Equal Tee 1" Dia, SE CL.3000	12	1,000	
15.	MS Elbow 1" Dia 90 Screwed 0.179 CWP-3000. A.105N	18	250	
16.	Union 1" dia, SE.CWP 3000	18	550	
17.	Socket MS size 1", CI:2000, GR.2	12	600	
18.	Orifice Plate. SS- 316, Size: 0.75, Outer Dia 2"-1/8"	04	20,000	

**Notes:-**

- Bidder must conform to the specified tender terms.
- Free delivery at our specified store including all Taxes / Duties included in your quoted prices duly supported by documentary evidence.
- Each item will be evaluated separately.
- As a result of evaluation / scrutiny of bid, if any clarification is sought by SNGPL, bidders are required to adhere to the timeline specified by the SNGPL. In case of non-compliance to the timeline, SNGPL reserves the right to proceed further without any recourse.
- We require delivery as per above mentioned schedule / period, you however may quote your best delivery schedule period.
- Material should be supplied as per our specification, sub-standard / defective material will have to be replaced by you on 'NO CHARGE BASIS' even after our acceptance.
- Bidders are required to complete "Appendix-I" (Questionnaire Form) attached with the tender enquiry and return it with their quotation.
- The Company reserves the right to extend the opening date of tender enquiry without assigning any reason and to accept or to reject any offer without assigning any reasons.
- In case goods supplied by you are found sub-standard at any stage, you will be required to replace at your own cost within 7-days of receipt of written letter from us to that effect.
- Your offer should be accompanied by a copy of valid Sales Tax Registration, NTN and Professional Tax clearance certificate in your name, failing which the offer will not be considered for evaluation.
- Sales Tax will be paid to you on submission of documentary evidence.
- Conditional offer will not be considered for evaluation.**
- Bidder in their quotation write the prices in figures as well as in words. In case of any dispute between unit price, and total price, the unit price shall prevail.
- Discount, if any, should be boldly shown under the prices. Discount, if conditional or not read at the time of bid opening shall not be considered during bid evaluation.
- We reserve the right to increase/decrease the quantities or cancel this enquiry in whole or in part before tender opening should our requirement change in the meantime. After tender opening, the quantities may be increased / decrease by 15% of tender quantities. However, decrease beyond 15% shall be subject to concurrence by the successful bidder.
- Your deliveries are liable to be tested / physically inspected by us and if you fail to supply the material according to our specifications we reserve the right to cancel the purchase order.
- Bids will be evaluated and accepted for above offered quantity. No bid will be acceptable for less than the quantity specified above in the schedule of requirement.
- Please note that only firm and irrevocable offer will be considered for evaluation and acceptance, and no offer which contains any conditions such as the quoted price linked with foreign exchange rates, custom duty and transportation etc. will not be considered for acceptance.

New Tender Enquiries

18.	Please indicate clearly your reservations if any, to the terms and conditions of the tender enquiry, on the quotation.
19.	It is contractor's responsibility to take measures as per General Procedure of HSE in view of the environmental health, safety law and regulations. which is available at <a href="http://www.sngpl.com.pk">www.sngpl.com.pk</a> .
20.	The bidder is required to be on <b>Active Taxpayer List of FBR</b> for obtaining tender documents and quoting bid against tender enquiry.
21.	<p>The following documents / information must be provided along with the bid:-</p> <ul style="list-style-type: none"><li>➤ Name of the bidder.</li><li>➤ Type of ownership i.e. Proprietor / Partnership / Private Limited Company /Public Limited Company.</li></ul> <p>Following relevant papers must be provided in respective cases:-</p> <ul style="list-style-type: none"><li>➤ Copy of NIC in case of single proprietor</li><li>➤ Copy of Partnership deed in case of partnership</li><li>➤ Copy of Article of Association for Private / Public Limited Companies.</li><li>➤ Date of establishment of business concern.</li><li>➤ GST Number alongwith copy of certificate.</li><li>➤ National Tax Number alongwith copy of certificate.</li><li>➤ Professional Tax Clearance Certificate (2022-23)</li></ul>
22.	<p>Please provide your firm's official E-mail ID &amp; Website (if any) Contact Numbers in your bid for correspondence.</p> <ul style="list-style-type: none"><li>➤ E-Mail ID.</li><li>➤ Website.</li><li>➤ Contact Numbers.</li></ul>

## TECHNICAL SPECIFICATIONS

### ITEM # 1

#### Equalizing Pad Assembly 1/2 " 3-way Valve

Type	3 Valve (3- way)
Process Connection Sizes	1/2" NPT-Female
Connection Difference (center to center)	2- 5/8"
Application	Air or Natural Gas
Required for	differential Pressure equipment
Block Valves	2 for instrument isolation and 1 for equalization
Body Material	SS 316L
Packing Material	PTFE
Ball/Tip Material	316 SST
Stem Material	316 SST
Bonnet, Pipe Plug	316 SST
Seat	Integral
Pressure & Temperature Rating	4000 Psig @ 400 °F or 6000 Psig @ 200 °F
Test/vent Ports	1/4"
Bolts Material	Plated Carbon steel as per ASTM A449, type 1

- Factory assembled, Leak tested and calibrated
- Compact Light weight design
- Direct-mount capability

## TECHNICAL SPECIFICATIONS

### ITEM # 4, 5, 6, & 7

#### TUBING CLAMPS

Tubing Clamp	P- Clamp
Size	1", 3/4", 1/2" & 3/8"
Material	Stainless Steel Clamp, EPDM cushioned
Temperature Rating	-40 °F to 212 °F

Clamps must be strong, reliable retention and assure dimensional stability.

Clamps provided with self-retaining Speed Nut Fastener.

Clamps to be install easily to a wall or equipment frame using a single screw or bolt.

## TECHNICAL SPECIFICATIONS

### ITEM # 18

### ORIFICE PALTE 2"

NINE (09) NOS. OF ORIFICE PLATES REQUIRED WITH FOLLOWING SPECIFICATIONS.

SAMPLE PICTURE:

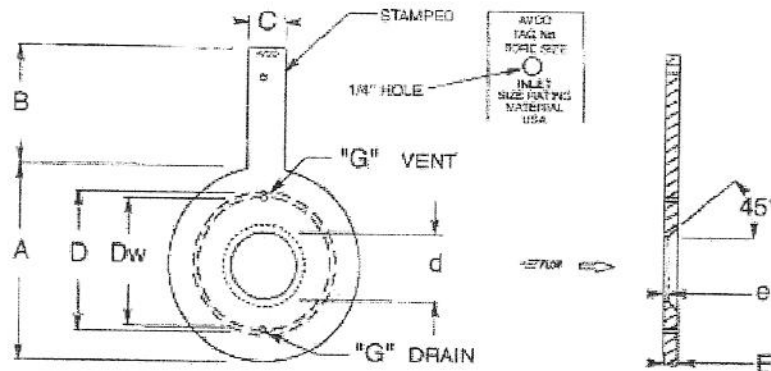

- D = Inside Line I.D.
- d = Orifice Bore Diameter
- G = Vent & Drain Hole Diameter
- E = Orifice Plate Thickness
- Dw = Diameter of Vent & Drain Hole Circle
- e = Orifice Throat Thickness
- emax = The Smaller of D/50 or d/8

**PLATE SIZE ACCORDING TO ABOVE PICTURE:**

PARAMETER	VALUE
A	4.37"
B	4"
C	1.25"
D	2.067"
DW	1.932"
E	1/8"
e	1/32"
d	4 mm (initial)